

◆Shape/外觀：



◆Specifications / 規格表：

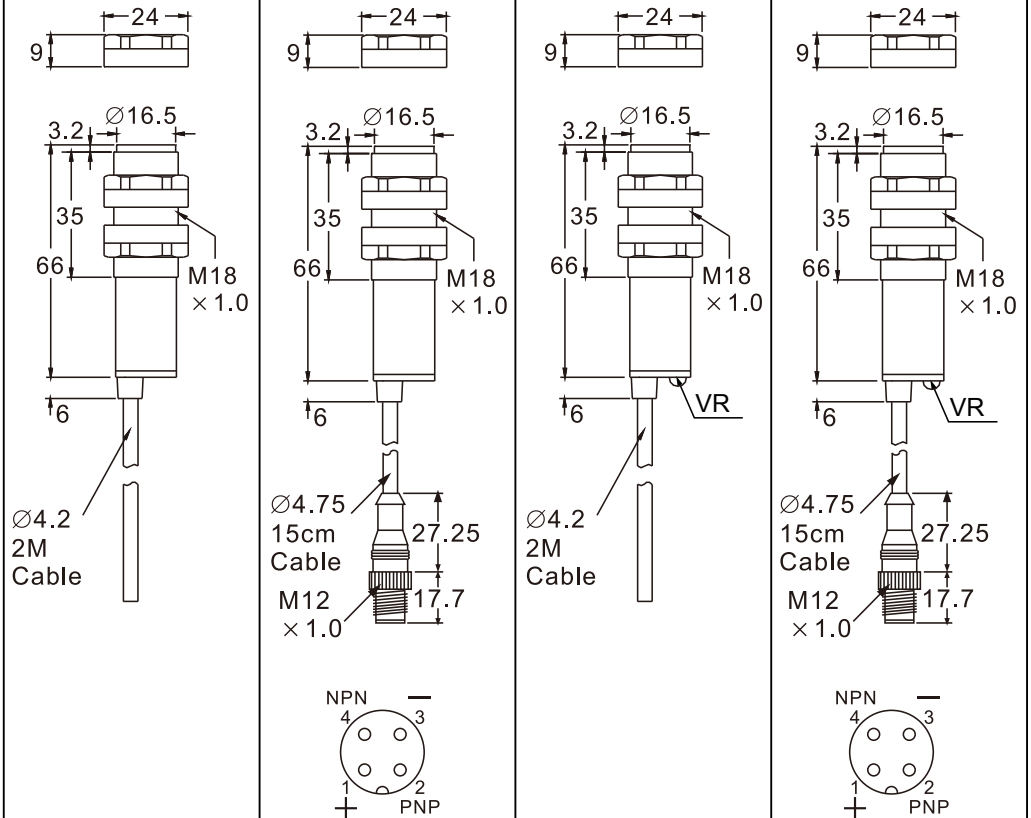

Model / 型號	RMF-10KP2	RMF-10KP2K	RMF-DU30KP2	RMF-DU30KP2K
Sensing type / 檢出方式	Through beam / 對照式		Diffuse reflection / 擴散反射式	
Sensing distance / 檢出距離	10M		30 cm	
Emitting light / 發光源	Infrared LED 850 nm		Infrared LED 875 nm	
Operating voltage / 工作電壓	DC12 ~ 24 V			
Current Consumption / 消耗電流	45 mA Max./Each side		30 mA Max.	
Load current / 負載電流	100mA Max. at DC24V			
Output type / 輸出模式	NPN N.O./N.C.		PNP N.O./N.C.	
Response time / 反應時間	1.5 ms Max.			
Insulation resistance / 隔離阻抗	20MΩ min. (DC500V)			
Voltage withstandability / 絕緣耐壓	AC1000V 60Hz for 60 Sec.			
Operating temperature / 工作溫度	- 25 °C ~ + 60 °C			
Ambient humidity / 工作溼度	35% ~ 85% RH			
Protection degree / 防水等級	IP66			
Material / 外觀材質	ABS			
Wiring method / 出線方式	Pre-wired Ø5.2 x 2 M / 4-wires	M12 pigtailed type / M12 接頭15cm電線式	Pre-wired Ø4.2 x 2M / 4-wires	M12 pigtailed type / M12 接頭15cm電線式
Weight / 重量	Approx.160g	Approx.60g	Approx.80g	Approx.40g

◆Dimensions/尺寸圖：



Tubular Photo Sensor

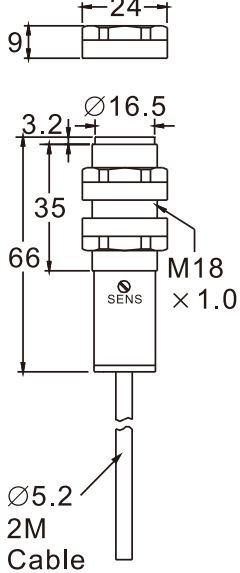
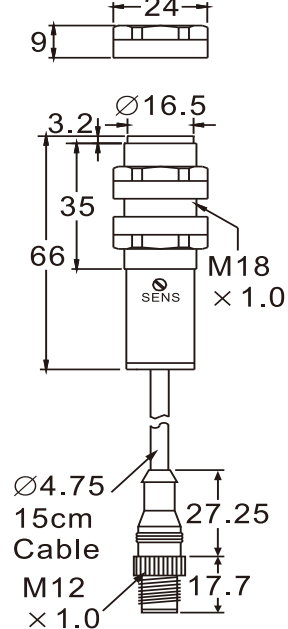
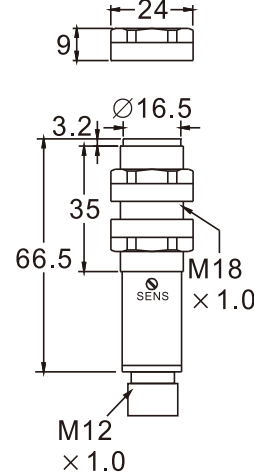
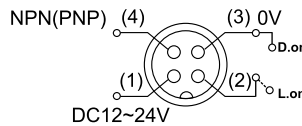

<p>◆Shape/外觀 :</p> <p>◆Specifications / 規格表 :</p>				Photo Sensor
<p>Model / 型號</p>	<p>RMF-DU10□ RMF-DU40□</p>	<p>RMF-DU10□K RMF-DU40□K</p>	<p>RMF-DU10□K1 RMF-DU40□K1</p>	Area Sensor
<p>Sensing type / 檢出方式</p>	<p>Diffuse reflection / 擴散反射式</p>			Inductive Proximity Sensor
<p>Sensing distance / 檢出距離</p>	<p>10 cm 40 cm</p>			Capacitive Proximity Sensor
<p>Emitting light / 發光源</p>	<p>Infrared LED 875 nm</p>			Timer / Counter
<p>Operating voltage / 工作電壓</p>	<p>DC12 ~ 24 V</p>			Others
<p>Current Consumption / 消耗電流</p>	<p>25 mA Max.</p>			Accessories
<p>Load current / 負載電流</p>	<p>200mA Max. at DC24V</p>			
<p>Output type / 輸出模式</p>	<p>□N : NPN L.on/D.on / □P : PNP L.on/D.on</p>			
<p>Response time / 反應時間</p>	<p>1.5 ms Max.</p>			
<p>Insulation resistance / 隔離阻抗</p>	<p>20MΩ min. (DC500V)</p>			
<p>Voltage withstandability / 絕緣耐壓</p>	<p>AC1000V 60Hz for 60 Sec.</p>			
<p>Operating temperature/工作溫度</p>	<p>- 20 °C ~ + 60 °C</p>			
<p>Ambient humidity / 工作溼度</p>	<p>35% ~ 85% RH</p>			
<p>Protection degree / 防水等級</p>	<p>IP66</p>			
<p>Material / 外觀材質</p>	<p>ABS</p>			
<p>Wiring method / 出線方式</p>	<p>Pre-weird Ø5.2 x 2 M / 4-wires</p>	<p>M12 pigtailed connector type / M12 接頭15cm電線式</p>	<p>M12 plug-in connector type / M12 接頭</p>	
<p>Weight / 重量</p>	<p>Approx.85g</p>	<p>Approx.35g</p>	<p>Approx.20g</p>	
<p>◆Dimensions/尺寸圖 :</p>				
				

◆Shape/外觀：



◆Specifications / 規格表：

Model / 型號	RMF-10□ RMF-20□	RMF-10□K RMF-20□K	RMF-10□K1 RMF-20□K1
Sensing type / 檢出方式	Through beam / 對照式		
Sensing distance / 檢出距離	10 M 20 M		
Emitting light / 發光源	Infrared LED 850 nm		
Operating voltage / 工作電壓	DC12 ~ 24 V		
Current Consumption / 消耗電流	45 mA Max.		
Load current / 負載電流	200mA Max. at DC24V		
Output type / 輸出模式	□N : NPN L.on/D.on / □P : PNP L.on/D.on		
Response time / 反應時間	1.5 ms Max.		
Insulation resistance / 隔離阻抗	20MΩ min. (DC500V)		
Voltage withstandability / 絕緣耐壓	AC1000V 60Hz for 60 Sec.		
Operating temperature/工作溫度	- 20 °C ~ + 55°C		
Ambient humidity / 工作溼度	35% ~ 85% RH		
Protection degree / 防水等級	IP66		
Material / 外觀材質	ABS		
Wiring method / 出線方式	RX:Pre-wired / 4-wire Ø5.2 x 2 M TX:Pre-wired / 2-wire Ø5.2 x 2 M	M12 pigtailed connector type / M12 接頭15cm電線式	M12 plug-in connector type / M12 接頭
Weight / 重量	Approx.165g	Approx.70g	Approx.40g
◆Dimensions/尺寸圖：	<p>Dimensions for RMF-10□ and RMF-20□: Total length: 66 mm Cable length: 2M Cable diameter: Ø5.2 Mounting hole diameter: Ø16.5 Mounting hole depth: 3.2 mm Mounting hole offset: 9 mm Mounting hole diameter: M18 × 1.0</p>	<p>Dimensions for RMF-10□K and RMF-20□K: Total length: 66 mm Cable length: 15cm Cable diameter: Ø4.75 Mounting hole diameter: Ø16.5 Mounting hole depth: 3.2 mm Mounting hole offset: 9 mm Mounting hole diameter: M18 × 1.0 Connector length: 27.25 mm Connector diameter: Ø12 mm Connector offset: 17.7 mm</p>	<p>Dimensions for RMF-10□K1 and RMF-20□K1: Total length: 66.5 mm Cable length: 15cm Cable diameter: Ø4.75 Mounting hole diameter: Ø16.5 Mounting hole depth: 3.2 mm Mounting hole offset: 9 mm Mounting hole diameter: M18 × 1.0 Connector length: 27.25 mm Connector diameter: Ø12 mm Connector offset: 17.7 mm</p>

Tubular Photo Sensor

RMF

◆Shape/外觀：

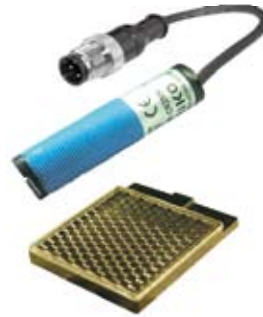

◆Specifications / 規格表：

Model / 型號	RMF-CR2□	RMF-CR2□K	RMF-CR2□K1
Sensing type / 檢出方式	Retroreflective / 鏡片反射式		
Sensing distance / 檢出距離	2M		
Emitting light / 發光源	Infrared LED 940 nm		
Operating voltage / 工作電壓	DC12 ~ 24 V		
Current Consumption / 消耗電流	25 mA Max.		
Load current / 負載電流	200mA Max. at DC24V		
Output type / 輸出模式	□N : NPN L.on/D.on / □P : PNP L.on/D.on		
Response time / 反應時間	1.5 ms Max.		
Insulation resistance / 隔離阻抗	20MΩ min. (DC500V)		
Voltage withstandability / 絕緣耐壓	AC1000V 60Hz for 60 Sec.		
Operating temperature/工作溫度	- 20 °C ~ + 60 °C		
Ambient humidity / 工作溼度	35% ~ 85% RH		
Protection degree / 防水等級	IP66		
Material / 外觀材質	ABS		
Wiring method / 出線方式	Pre-weird Ø5.2 x 2 M / 4-wires	M12 pigtailed connector type / M12 接頭15cm電線式	M12 plug-in connector type / M12 接頭
Weight / 重量	Approx.85g	Approx.35g	Approx.20g

◆Dimensions/尺寸圖：

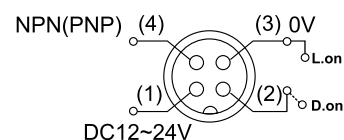
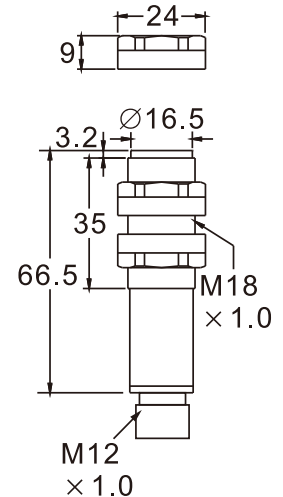
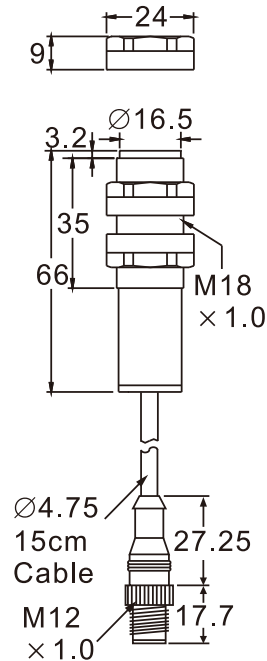
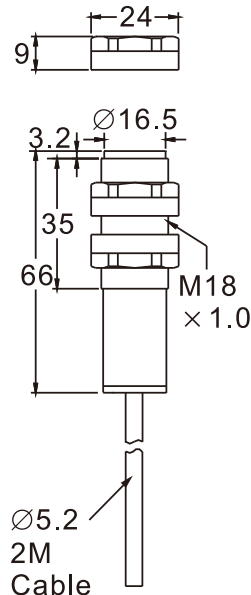

Photo Sensor

Area Sensor



Inductive Proximity Sensor

Capacitive Proximity Sensor

Timer / Counter

Others

Accessories

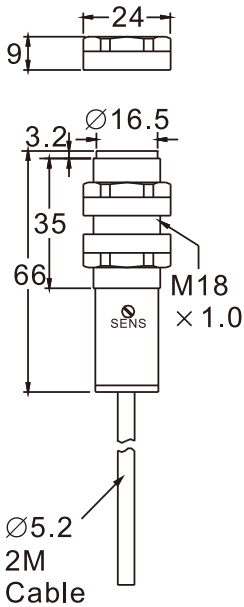
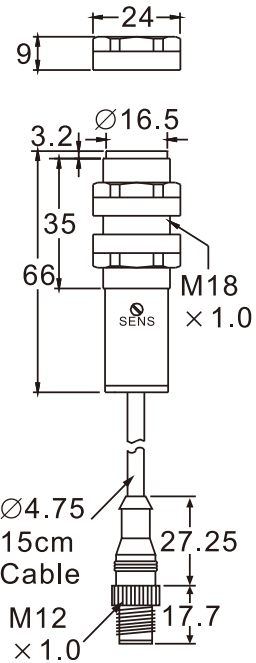
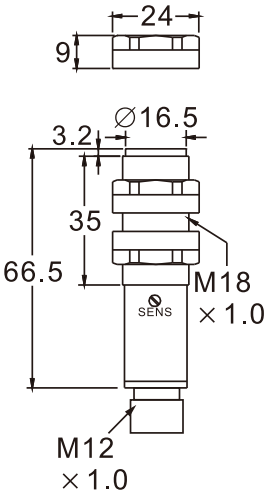
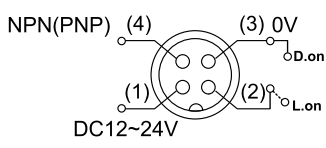
Photo Sensor	◆Shape/外觀 :			
Area Sensor	◆Specifications / 規格表 :			
Inductive Proximity Sensor	Model / 型號	MMF-DU10□ MMF-DU40□	MMF-DU10□K MMF-DU40□K	MMF-DU10□K1 MMF-DU40□K1
Capacitive Proximity Sensor	Sensing type / 檢出方式	Diffuse reflection / 擴散反射式		
	Sensing distance / 檢出距離	10 cm 40 cm		
	Emitting light / 發光源	Infrared LED 875 nm		
	Operating voltage / 工作電壓	DC12 ~ 24 V		
	Current Consumption / 消耗電流	25 mA Max.		
	Load current / 負載電流	200mA Max. at DC24V		
	Output type / 輸出模式	[N] : NPN L.on/D.on / [P] : PNP L.on/D.on		
	Response time / 反應時間	1.5 ms Max.		
	Insulation resistance / 隔離阻抗	20MΩ min. (DC500V)		
	Voltage withstandability / 絕緣耐壓	AC1000V 60Hz for 60 Sec.		
	Operating temperature/工作溫度	- 20 °C ~ + 60°C		
	Ambient humidity / 工作溼度	35% ~ 85% RH		
	Protection degree / 防水等級	IP66		
	Material / 外觀材質	Nickel plated brass		
Timer / Counter	Wiring method / 出線方式	Pre-wired Ø5.2 x 2 M / 4-wires	M12 pigtailed connector type / M12 接頭15cm電線式	M12 plug-in connector type / M12 接頭
Others	Weight / 重量	Approx.105g	Approx.50g	Approx.40g
Accessories	◆Dimensions/尺寸圖 :			
				

Tubular Photo Sensor

MMF

◆Shape/外觀：



◆Specifications / 規格表：

Model / 型號	MMF-10 □ MMF-20 □	MMF-10 □ K MMF-20 □ K	MMF-10 □ K1 MMF-20 □ K1
Sensing type / 檢出方式	Through beam / 對照式		
Sensing distance / 檢出距離	10 M 20 M		
Emitting light / 發光源	Infrared LED 850 nm		
Operating voltage / 工作電壓	DC12 ~ 24 V		
Current Consumption / 消耗電流	45 mA Max.		
Load current / 負載電流	200mA Max. at DC24V		
Output type / 輸出模式	[N] : NPN L.on/D.on / [P] : PNP L.on/D.on		
Response time / 反應時間	1.5 ms Max.		
Insulation resistance / 隔離阻抗	20MΩ min. (DC500V)		
Voltage withstandability / 絕緣耐壓	AC1000V 60Hz for 60 Sec.		
Operating temperature/工作溫度	- 25 °C ~ + 55 °C		
Ambient humidity / 工作溼度	35% ~ 85% RH		
Protection degree / 防水等級	IP66		
Material / 外觀材質	Nickel plated brass		
Wiring method / 出線方式	RX:Pre-wired / 4-wires Ø5.2x2 M TX:Pre-wired / 2-wires Ø5.2x2 M	M12 pigtailed connector type / M12 接頭15cm電線式	M12 plug-in connector type / M12 接頭
Weight / 重量	Approx.210g	Approx.100g	Approx.80g

◆Dimensions/尺寸圖：

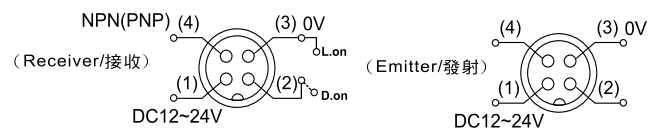
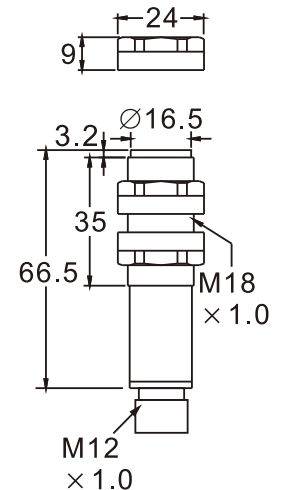
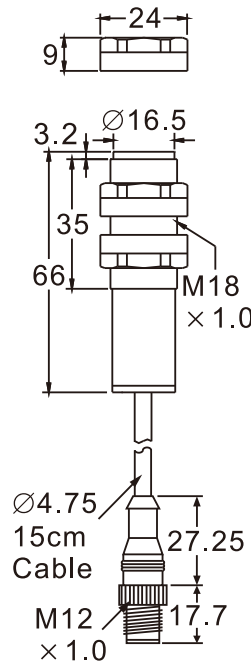
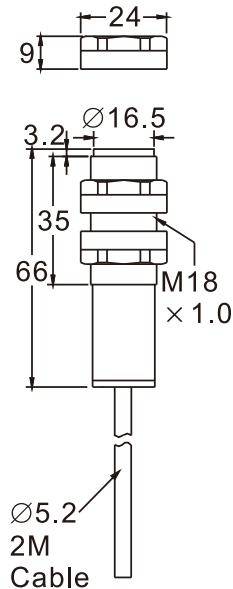

Photo Sensor

Area Sensor

Inductive Proximity Sensor

Capacitive Proximity Sensor

Timer / Counter

Others

Accessories

◆Shape/外觀：



◆Specifications / 規格表：

Model / 型號	MMF-CR2□	MMF-CR2□K	MMF-CR2□K1
Sensing type / 檢出方式	Retroreflective / 鏡片反射式		
Sensing distance / 檢出距離	2M		
Emitting light / 發光源	Infrared LED 940 nm		
Operating voltage / 工作電壓	DC12 ~ 24 V		
Current Consumption / 消耗電流	25 mA Max.		
Load current / 負載電流	200mA Max. at DC24V		
Output type / 輸出模式	□N : NPN L.on/D.on / □P : PNP L.on/D.on		
Response time / 反應時間	1.5 ms Max.		
Insulation resistance / 隔離阻抗	20MΩ min. (DC500V)		
Voltage withstandability / 絕緣耐壓	AC1000V 60Hz for 60 Sec.		
Operating temperature/工作溫度	- 20 °C ~ + 60°C		
Ambient humidity / 工作溼度	35% ~ 85% RH		
Protection degree / 防水等級	IP66		
Material / 外觀材質	Nickel plated brass		
Wiring method / 出線方式	Pre-wired Ø5.2 x 2 M / 4-wires	M12 pigtailed connector type / M12 接頭15cm電線式	M12 plug-in connector type / M12 接頭
Weight / 重量	Approx.105g	Approx.50g	Approx.40g

◆Dimensions/尺寸圖：

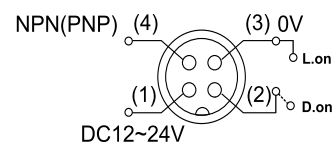
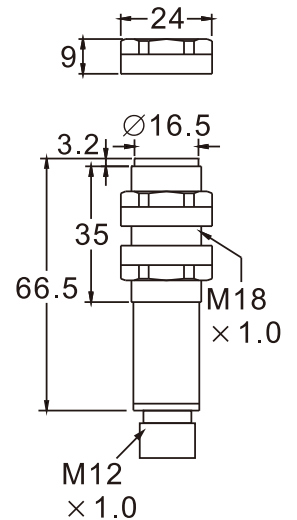
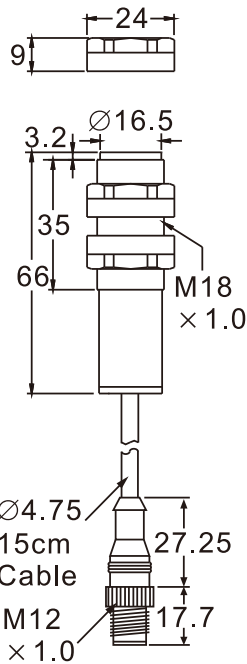
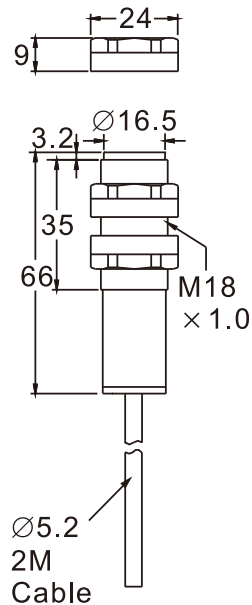

◆Characteristics / 特點：

- Using high brightness red LED, its light-spot is visible and clear.
/採用超高亮度紅色發光LED，光點清晰可見。



◆Specifications / 規格表：

Model / 型號	MMF-QR2□	MMF-QR2□K	MMF-QR2□K1
Sensing type / 檢出方式	Retroreflective(Red LED) / 鏡片反射式(紅光)		
Sensing distance / 檢出距離	2M		
Emitting light / 發光源	Red LED 650 nm		
Operating voltage / 工作電壓	DC12 ~ 24 V		
Current Consumption / 消耗電流	25 mA Max.		
Load current / 負載電流	200mA Max. at DC24V		
Output type / 輸出模式	□N : NPN L.on/D.on / □P : PNP L.on/D.on		
Response time / 反應時間	1.5 ms Max.		
Insulation resistance / 隔離阻抗	20MΩ min. (DC500V)		
Voltage withstandability / 絕緣耐壓	AC1000V 60Hz for 60 Sec.		
Operating temperature/工作溫度	- 20 °C ~ + 60°C		
Ambient humidity / 工作溼度	35% ~ 85% RH		
Protection degree / 防水等級	IP66		
Material / 外觀材質	Nickel plated brass		
Wiring method / 出線方式	Pre-wired Ø5.2 x 2 M / 4-wires	M12 pigtailed connector type / M12 接頭15cm電線式	M12 plug-in connector type / M12 接頭
Weight / 重量	Approx.105g	Approx.50g	Approx.40g

◆Dimensions/尺寸圖：

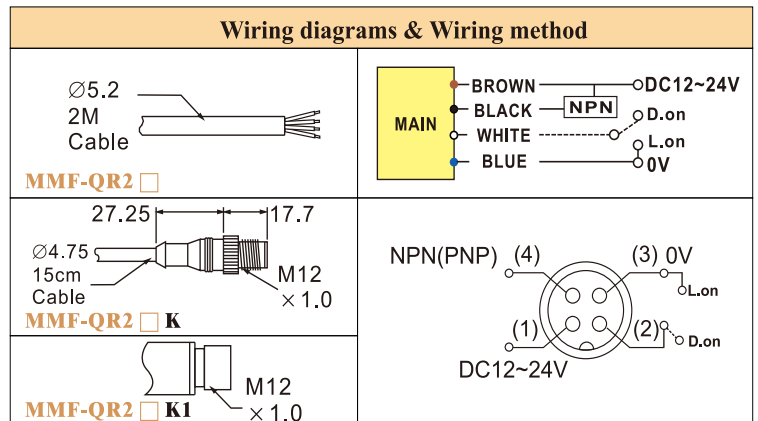
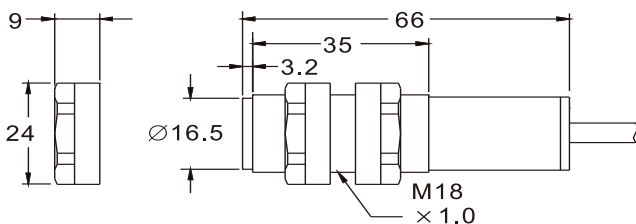



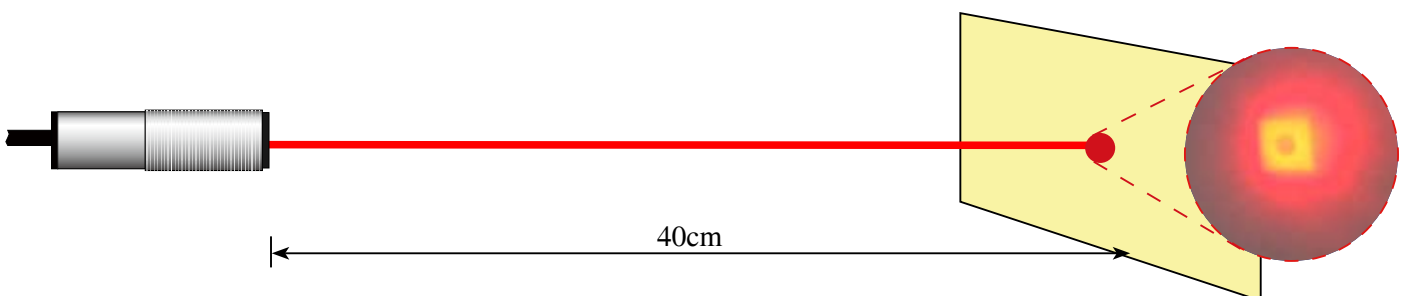

◆Clearly visible red LED / 清晰可見的紅光LED

The visible red LED is available at the distance of 40cm. It is easy for your installation and detection.
/使用紅光LED，即使在40cm的距離，一樣可以清楚的看見紅光，讓您在安裝檢測時更方便。

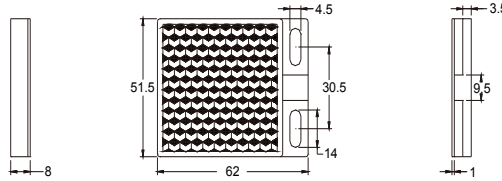

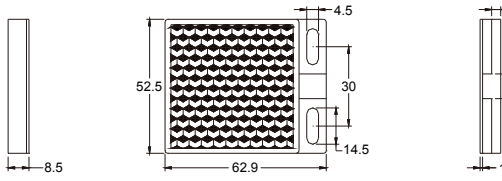

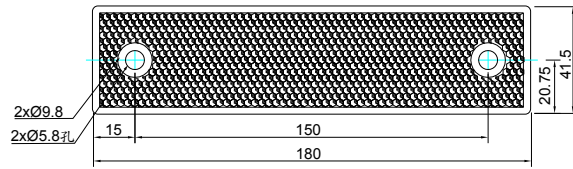

◆RR- 03 Reflectors / 鏡片 :

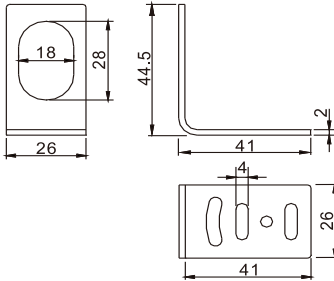
Model / 產品圖	Dimensions / 尺寸圖	Available Model/適用機種
		TQ18-R2□ Sensing Distance : 2M TQ18-PR1□ Sensing Distance : 1M (R/M)MF-CR2□ Sensing Distance : 2M (R/M)MF-QR2□ Sensing Distance : 2M
		TQ18-R2□ Sensing Distance : 3M TQ18-PR1□ Sensing Distance : 2M (R/M)MF-CR2□ Sensing Distance : 3M (R/M)MF-QR2□ Sensing Distance : 3M
		TQ18-R2□ Sensing Distance : 2M TQ18-PR1□ Sensing Distance : 2M (R/M)MF-CR2□ Sensing Distance : 2M (R/M)MF-QR2□ Sensing Distance : 2M

◆MF- 01 Mounting Bracket / 固定架 :

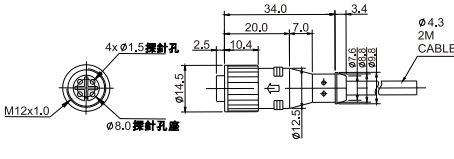
Model / 產品圖	Dimensions / 尺寸圖	Material	Available Model/適用機種
		Iron / 鐵	TQ18-□ / (R/M)MF-□ Series

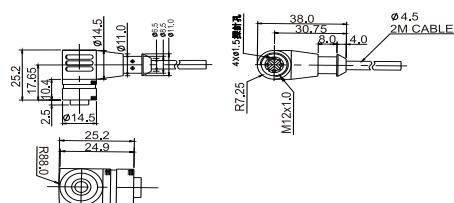
◆Connectors / 線材 (Optional mating cables) :

Model / 產品圖	Dimensions / 尺寸圖	Wire Color	Available Model/適用機種
		1-BROWN 2-WHITE 3-BLUE 4-BLACK	R3JK-□K Series Operation Instructions /R3JK-□K系列機種
		1-BROWN 2-WHITE 3-BLUE 4-BLACK	使用說明 Sensor side / 光電側  Machine side / 機台側  Foolproof device 