

2017

# Ingress Protection Illumination (IP-65)

## HPDP SERIES - Larger Uniform Ring Light Illumination

Ingress Protection Power LED with molded diffuser to achieve high uniform area with higher flexibility.

Application: shining surface and food packaging.

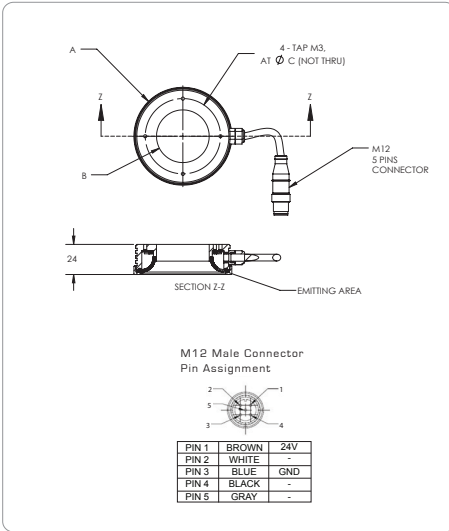
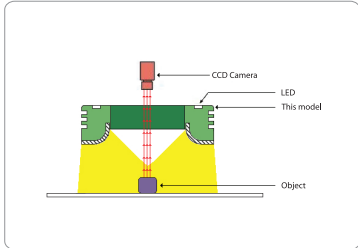

### Technical Specification:

- Color Red, Green, Blue and White
- 24V DC Input Power
- Continuous and Strobe Applications
- Compact Size
- Lighting Cable 500mm

### Customize Lighting:

- Customize Sizes, Mounting requirements
- Color and Voltage Available
- Consult Technical Sales for More Information

Model	Dimensions (MM)			Color	Voltage / Watt	Current	Weight (g)
	A	B	C				
HPDP-00-070-1-X	78.0	42	60.0	● ● ● ● ● ○	24V / 1.80W 24V / 2.16W	75mA 90mA	130
HPDP-00-110-2-X	116.4	68	90.0	● ● ● ● ● ○	24V / 3.96W 24V / 4.37W	165mA 182mA	200