



Motionnet MNET-S23 Single Axis Motion Control Board for Yaskawa Σ II, Σ III, Σ V series Servo

Specifications

Serial Communications

Item	Specifications
Cyclic communication times and data transfer cycles	Data transfer cycle Maximum of 0.49 msec, when using 32 devices. (*1) Maximum of 0.97 msec, when using 64 devices. (*2)
Total serial communication line length	Maximum of 100 m (*3) Maximum of 50 m (*4) Maximum of 100 m (*5)
Serial communication interface	RS-485 with transformer isolation Half duplex communication 2.5/5/10/20 Mbps transmission rate can be set by software (Default 20 Mbps)
Serial communication device number	63 Devices Maximum
LED indicator	RUN: While receiving serial communications normally, the green LED is lit. ERR: When a serial communication error occurs continuously, the red LED is lit.

Motion Control

Item	Specifications
Applicable servo driver	Servo pack Σ II, Σ III and Σ V series (pulse command supporting type) made by Yaskawa Electric (Direct connections to the CN1 I/O signal connector)
Positioning control range	-134,217,728 to 134,217,727 (28 bits)
Command counter setting range	-134,217,728 to 134,217,727 (28 bits)
Pulse rate setting range	1 - 65,535 (16-bit)
Pulse rate multiplier setting range	0.1 - 66.6
Pulse train frequency	Maximum of 6.6 Mpps, with a minimum of 0.1 pps Output Voltage: ➢ Logic H: 2.5V min. ➢ Logic L: 0.5V max
Command pulse output	Select from the types below based on the environment settings - CW/CCW method (2 pulse mode) - 90° phase difference method (AB phase pulse mode)
Encoder signal input interface (High Speed Isolation I/F)	Encoder A phase and B phase input: Maximum response frequency; 3.5 MHz Input Voltage: ➢ Logic H: 3 - 5 V ➢ Logic L: 0 - 2.4 V
Driver system Input (Isolation I/F)	Alarm input (ALM) Positioning complete input (INP) Servo ready input (SVRDY)
Driver system Output (Open collector output I/F)	Deflection counter clear output (ERC) Servo on output (SVON) Alarm reset output (ALMRES) Emergency stop output (EMGO)
Dedicated Mechanical Input (Isolation I/F)	Positive end limit input (PEL) Zero position input (ORG) Negative end limit input (MEL) Emergency stop input (EMGI) Slowdown input (SD)
Dedicated Mechanical Output (Differential output I/F)	Comparator output (CPP, CPN)

Note:

- (*1, *2) Data transfer speed: 20 Mbps, when using ADLINK recommended cable *1:100m, *: 50m
- (*3) Data transfer speed: 20 Mbps, with 32 devices connected by using ADLINK recommended cables
- (*4) Data transfer speed: 20 Mbps, with 64 devices connected by using ADLINK recommended cables
- (*5) Data transfer speed: 20 Mbps, with 64 devices connected by using ADLINK recommended cables

- Dimension:
W52.4 x D16.3 x H69.5 (Unit: mm)
- Weight: Approximately 50 g
- Operating Temperature: 0 to 50°C
- Operating ambient humidity: 80%RH or less (Non condensing through the 10°C to 50°C range)
- Power Consumption:
24 VDC±10%, 110 mA (Typ.)

Recycle Paper



Pin Assignment

CN1, 2 (serial communication connector)

Connect the Motionnet serial signal. The corresponding pins of CN1 and CN2 are internally connected.

No.	Signal name	Function	Signal direction	No.	Signal name	Function	Signal direction
1	RS485+	Serial communication data+	I/O	2	RS485-	Serial communication data-	I/O
3	FG	Frame ground	-	-	-	-	-

Note 1: The signal directions above refer to the signal flow direction as seen from the board: "I" = Input and "O" = Output.

Note 2: The FG above is connected to the FG on connector CN3.

CN3 (mechanical input/output, power supply connector)

Connect Mechanical system Input/Output signals and control power for the board.

No.	Signal name	Function	Signal direction	No.	Signal name	Function	Signal direction
1	PEL	Positive end limit	I	2	MEL	Negative end limit	I
3	SD/CPN	Slowdown input / comparator output (+)	I/O	4	ORG	Zero position input	I
5	EMGI	Emergency stop input	I	6	CPN	Comparator output (-)	O
7	24V	24VDC Power source	I	8	GND	Ground	I
9	GND	Ground	I	10	FG	Frame ground	-

Note 3: The signal directions above refer to the signal flow direction as seen from the board: "I" = Input and "O" = Output.

CN4 (servo driver connector)

Insert the control signal connector CN1 on the Servo pack Σ II, Σ III series (Yaskawa Electric) directly into this connector. The connector housing is also the frame ground.

Nbr.	Signal name	Function	Signal direction	Nbr.	Signal name	Function	Signal direction
1	GND	Ground		2	-	-	-
3	-	-	-	4	-	-	-
5	-	-	-	6	-	-	-
7	PULSP	Pulse signal (+)	O	8	PULSN	Pulse signal (-)	O
9	-	-	-	10	-	-	-
11	DIRP	Direction signal (+)	O	12	DIRN	Direction signal (-)	O
13	-	-	-	14	ERC	Deflection counter clear	O
15	ERCP	Deflection counter clear + common	O	16	-	-	-
17	-	-	-	18	-	-	-
19	EZN	Encoder Z phase (+)	I	20	EZP	Encoder Z phase (-)	I
21	-	-	-	22	-	-	-
23	-	-	-	24	-	-	-
25	INP	Positioning complete input	I	26	GND	Ground	O
27	-	-	-	28	-	-	-
29	SVRDY	Servo ready input	I	30	GND	Ground	O
31	ALM	Alarm	I	32	GND	Ground	O
33	EAP	Encoder A phase (+)	I	34	EAN	Encoder A phase (-)	I
35	EBP	Encoder B phase (+)	I	36	EBN	Encoder B phase (-)	I
37	-	-	-	38	-	-	-
39	-	-	-	40	SVON	Servo ON	O
41	-	-	-	42	GND	Ground	O
43	GND	Ground	O	44	ALMRES	Alarm reset output	O
45	-	-	-	46	-	-	-
47	24V	24 VDC power supply	O	48	-	-	-
49	-	-	-	50	-	-	-

Note 4: The signal directions above refer to the signal flow direction as seen from the board: "I" = Input and "O" = Output.
 Note 5: A blank means not connected.

Connector and Switch Information

The layout of the connectors and switches is shown below.

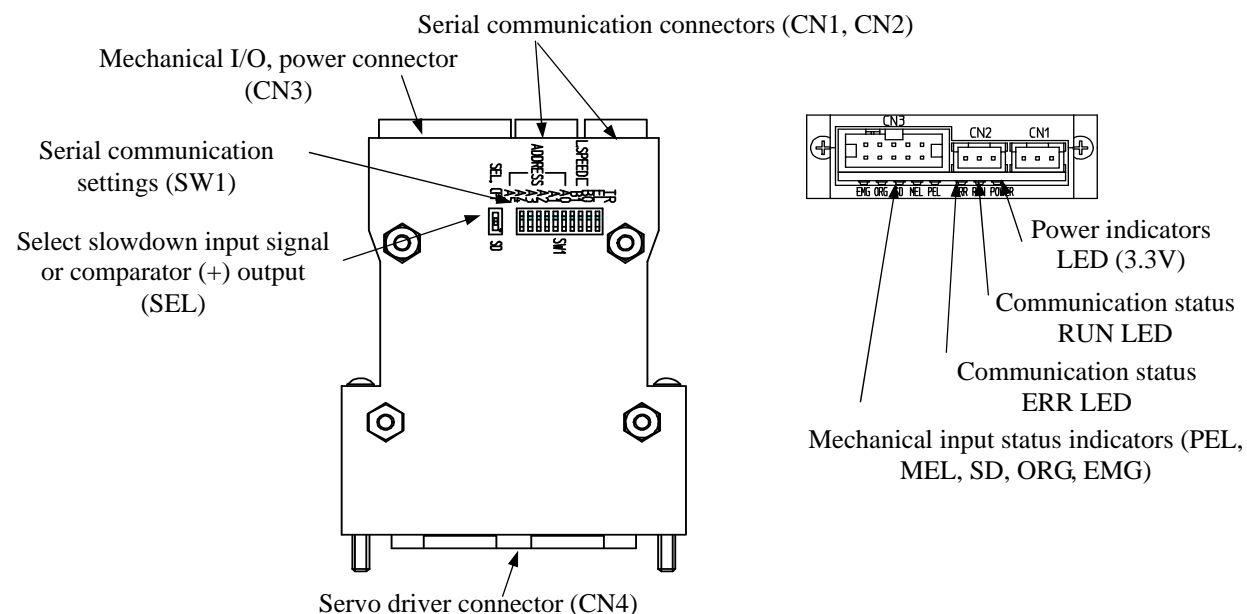

Item	Setting details	Item	Setting details												
Serial comm. device number assignment (SW1-A0 to 5)	Assign a device number for serial communication. (A0 to A5 correspond to 1, 2, 4, 8, 16, and 32. The sum of these values will be the device number.) (Default setting: All off)	Setting termination resistance (SW1-TR)	Setting termination resistance												
			<table border="1"> <tr><td>TR</td><td>Output status</td></tr> <tr><td>OFF</td><td>-</td></tr> <tr><td>ON</td><td>Insert a termination resistance</td></tr> </table> (Default setting: Off)	TR	Output status	OFF	-	ON	Insert a termination resistance						
TR	Output status														
OFF	-														
ON	Insert a termination resistance														
Setting the transfer speed (SW1-B0, B1)	Setting the transfer speed	Switching mechanical input/output (SEL)	Select slowdown input signal or comparator (+) output												
			<table border="1"> <tr><td>B0</td><td>B1</td><td>Transfer speed</td></tr> <tr><td>OFF</td><td>OFF</td><td>20Mbps</td></tr> <tr><td>ON</td><td>OFF</td><td>10Mbps</td></tr> <tr><td>OFF</td><td>ON</td><td>5Mbps</td></tr> <tr><td>ON</td><td>ON</td><td>2.5Mbps</td></tr> </table> (Default setting All off)	B0	B1	Transfer speed	OFF	OFF	20Mbps	ON	OFF	10Mbps	OFF	ON	5Mbps
B0	B1	Transfer speed													
OFF	OFF	20Mbps													
ON	OFF	10Mbps													
OFF	ON	5Mbps													
ON	ON	2.5Mbps													
Setting the PEL + MEL logic (SW1-EL)	Setting the logic for PEL + MEL														
				<table border="1"> <tr><td>EL</td><td>Logic</td></tr> <tr><td>OFF</td><td>The end limit signal goes on when the respective photocoupler turns on.</td></tr> <tr><td>ON</td><td>The end limit signal goes off when the respective photocoupler turns on.</td></tr> </table> (Default setting: ON)	EL	Logic	OFF	The end limit signal goes on when the respective photocoupler turns on.	ON	The end limit signal goes off when the respective photocoupler turns on.					
EL	Logic														
OFF	The end limit signal goes on when the respective photocoupler turns on.														
ON	The end limit signal goes off when the respective photocoupler turns on.														

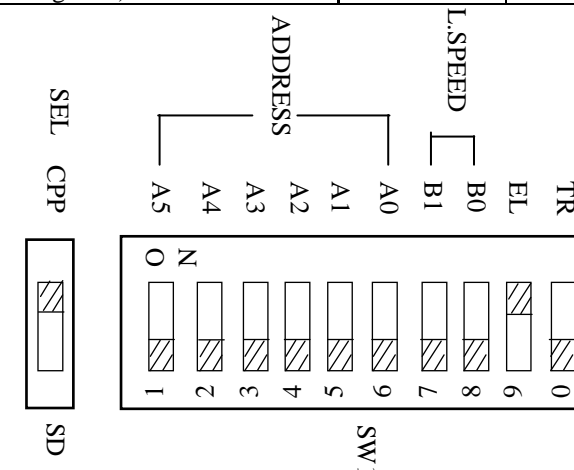

Ordering Information

- DB-8153: Single Motionnet master controller daughter board
- PCI-8154: Advanced 4-axis stepping & servo motion control card
- PCI-8158: Advanced 8-axis stepping & servo motion control card
- DPAC-3100: AMD LX-800 CPU with HSL and Motionnet bus
- DPAC-3200: Intel® Celeron® M 1GHz with HSL and Motionnet bus

ADLINK on the Internet

Homepage: www.adlinktech.com
 Service: service@adlinktech.com

Copyright © 2008 ADLINK Technology, Inc.
 TEL: 886-2-82265877 FAX: 886-2-82265717
 Contents and specification subject to change without notice.
 Motionnet® is a registered trademark of ADLINK Technology Inc.
 Other brands of products are trademarks or registered trademarks of their respective holders.



Dimensions

The external dimensions of MNET-S23 are shown below.

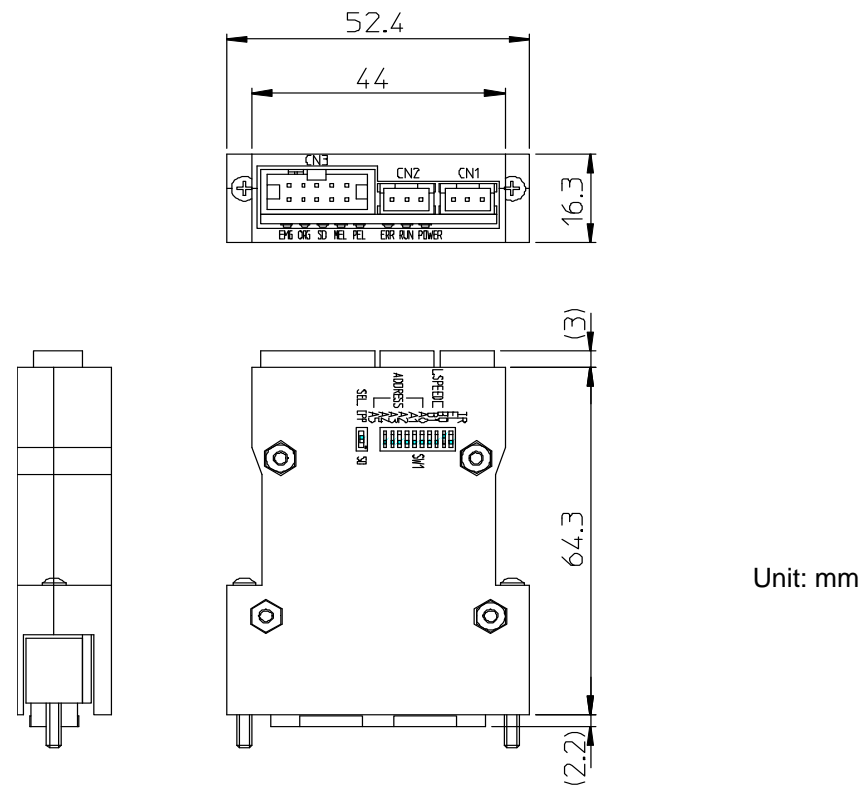

Unit: mm

Dimensions when connected to a servo pack (Σ III series)

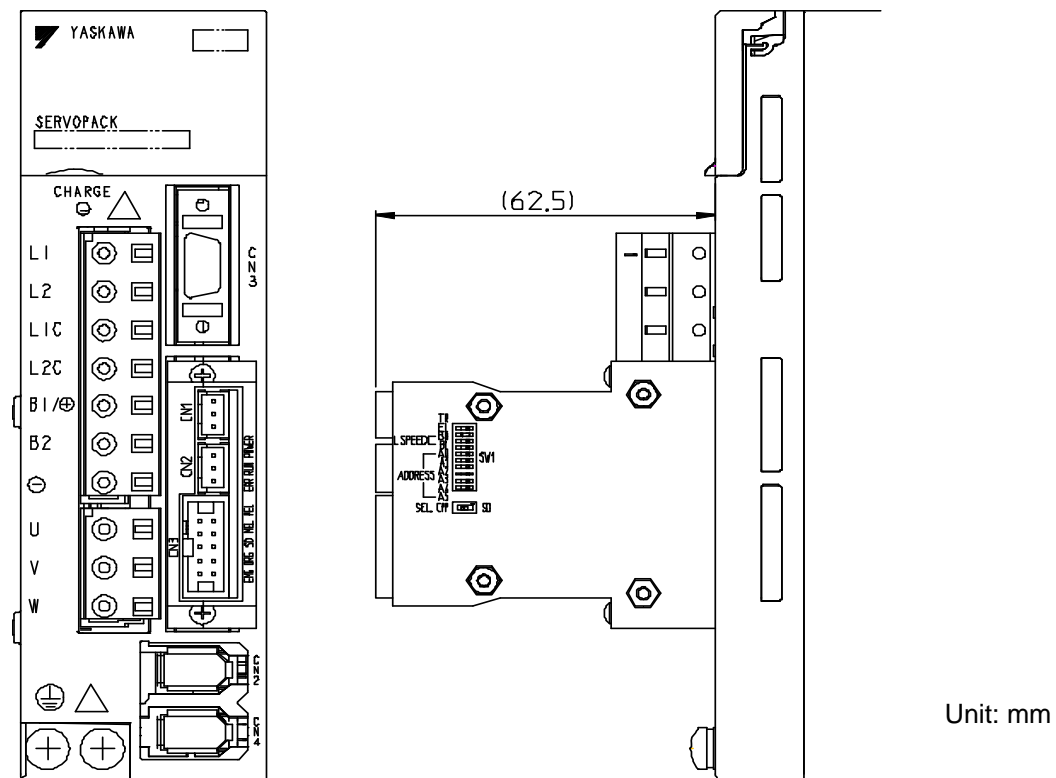

Unit: mm